

Châssis à chenilles.

Châssis:	Fabrication Liebherr, construction soudée en acier à résistance élevée, comprenant partie centrale, 2 poutres transversales et 2 porteurs-chenilles bipartites.
Train de roulement:	Train de roulement sans entretien et antisalissant, patins de chenille plats, largeur de patin: 2,5 m, écartement du train de roulement: 12,5 m.
Entraînement:	Par porteur-chenille, 2 entraînements hydrauliques aux engrenages planétaires. Chaînes à chenille à commande individuelle et en sens opposé.

Partie tournante.

Châssis:	Fabrication Liebherr, construction soudée en acier à résistance élevée. Liaison au châssis à chenilles par couronne d'orientation à 3 rangées de rouleaux, dotée d'un dispositif de liaison rapide. Orientation à 360°. Partie tournante divisée.
Moteur:	12 cylindres, Cummins, type KTA 38 C 1050, 746 kW (1014 ch) à 1800 min ⁻¹ .
Entraînement:	Hydraulique par boîte transfert de pompe et 5 pompes à pistons axiaux à débit variable, asservissement de capacité, circuits hydrauliques fermés.
Commande de grue:	Servocommande, dispositif de synchronisation au treuils de levage, recyclage d'énergie en abaissant une charge. Tous les mouvements de travaux sont exécutés individuellement moyennant de combineurs, type mache à balai.
Treuils:	5 - 6 treuils, entraînement hydraulique par pompe à pistons axiaux à débit variable et engrenages planétaires. Freins à disques multiples commandés par ressort et à desserrage hydraulique.
Mécanismes d'orientation:	1 à 3 mécanismes d'orientation, entraînement hydraulique par pompe à pistons axiaux et engrenage planétaire, frein à disques multiples commandé par ressort et à desserrage hydraulique. Vitesse d'orientation à réglage continu.
Contrepoids:	Env. 400 t, comprenant: 1 plaque à 14 t et 26 plaques à 15 t.
Cabine:	En tôle d'acier, vitres de sécurité, orientable latéralement et inclinable en arrière. Organes de commande et de contrôle.
Système électrique:	24 V continu, 2 batteries à 143 Ah.

Configurations de flèche.

Conception lourde:	S - SH - SN - SNH - SNF - SD - SDH - SDBW - SDN - SDNH - SDNBW - SDNF - SDWBW.
Équipement optionnel:	Remorque à lest pour 600 t de capacité totale.

LR 11200

Raupenkran Crawler Crane Grue sur chenilles

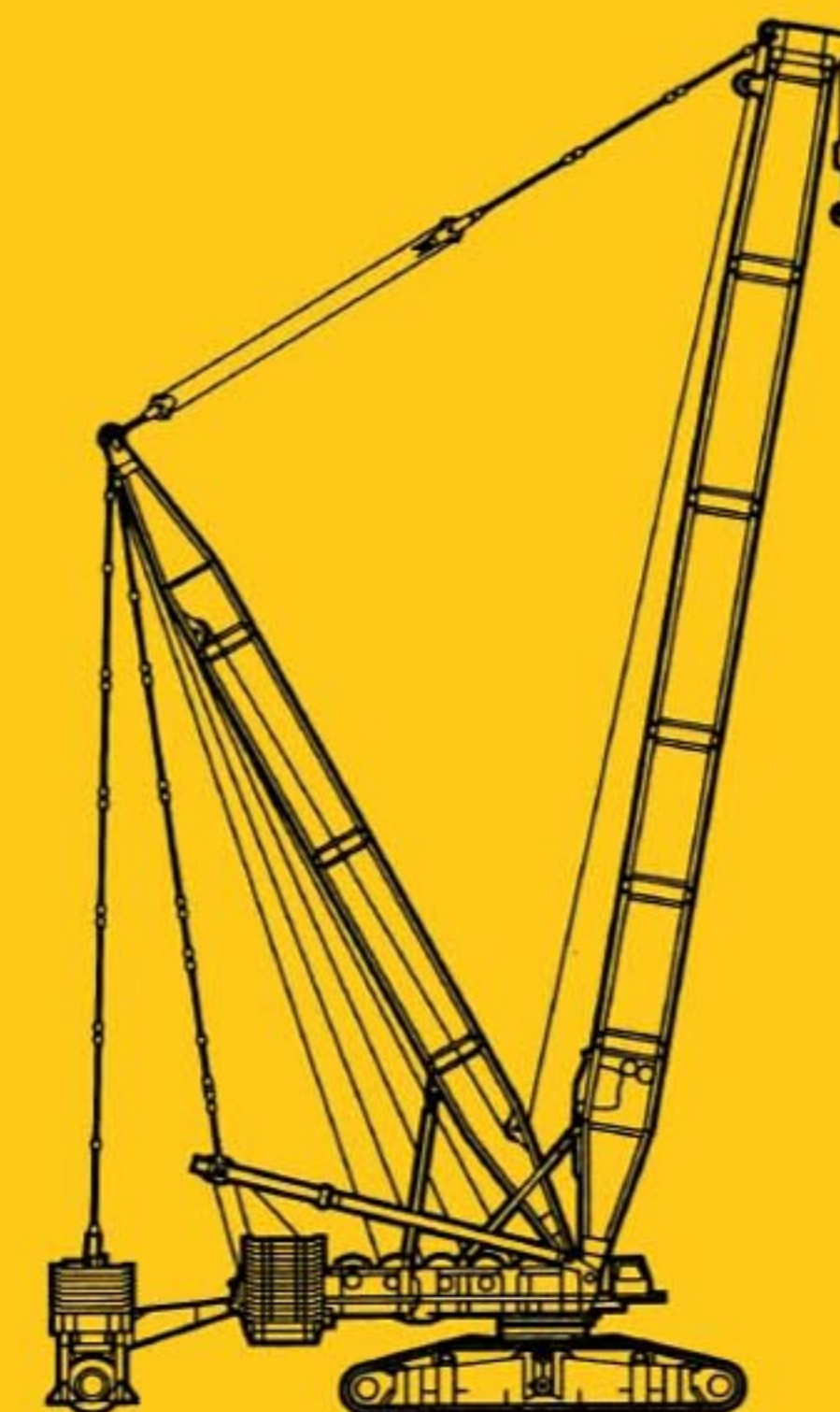

Die Traglasten am S-Ausleger. Lifting capacities at S boom. Forces de levage à la flèche principale S.

LR 11200



↔ m	42 m	49 m	56 m	63 m	70 m	77 m	84 m	91 m	98 m	↔ m
10	1000									10
11	940	935	930							11
12	882	858	852	850	820					12
14	738	733	728	726	720	717	640			14
16	644	639	634	631	625	622	618	563	496	16
18	570	565	559	557	551	548	544	540	480	18
20	510	505	499	496	491	487	484	480	470	20
22	460	455	450	447	441	438	434	431	427	22
24	419	414	409	406	400	396	392	389	385	24
26	383	379	373	370	365	361	357	354	350	26
28	353	348	343	340	334	331	327	323	319	28
30	327	322	317	314	308	304	300	297	293	30
32	304	299	294	290	285	281	277	274	269	32
34	283	279	273	270	264	261	256	250	245	34
36	265	260	255	252	246	241	235	230	224	36
38	249	244	239	235	228	222	217	211	206	38
40	234	230	224	219	212	206	200	194	189	40
44		203	196	191	184	178	172	166	161	44
48			174	168	161	155	149	143	137	48
52			154	149	142	136	130	124	118	52
56				133	126	119	113	107	101	56
60					113	106	99	93	87	60
64					101	94	87	81	74	64
68						83	77	70	64	68
72							67	61	54	72
76							59	52	46	76
80								45	38	80
84									32	84
88									26	88
m/s*	14	14	14	13	13	13	13	11	11	m/s*

* Zulässige Windgeschwindigkeit.
Permissible wind speed.
Vitesse du vent admissible.

TAB 58041

Anmerkungen zu den Traglasttabellen.

- Die angegebenen Traglasten überschreiten nicht 75 % der Kipplast.
- Für die Kranberechnungen gelten die DIN-Vorschriften lt. neuem Gesetz gemäß Bundesarbeitsblatt vom 2/85: Die Traglasten 75 % (Standstabilität) entsprechen DIN 15019, Teil 2. Für die Stahltragwerke gilt DIN 15018, Teil 3. Die bauliche Ausbildung des Krans entspricht DIN 15018, Teil 2 sowie der F. E. M.
- Die Traglasten sind in Tonnen angegeben.
- Das Gewicht des Lasthakens bzw. der Hakenflasche ist von den Traglasten abzuziehen.
- Die Ausladungen sind von Mitte Drehkranz gemessen.

Remarks referring to load charts.

- The tabulated lifting capacities do not exceed 75 % of the tipping load.
- When calculating crane stresses and loads, German Industrial Standards (DIN) are applicable, in conformity with new German legislation (published 2/85): the 75 % lifting capacities (stability margin) are as laid down in DIN 15019, part 2. The crane's structural steelwork is in accordance with DIN 15018, part 3. Design and construction of the crane comply with DIN 15018, part 2, and which F. E. M. regulations.
- Lifting capacities are given in metric tons.
- The weight of the hook blocks and hooks must be deducted from the lifting capacities.
- Working radii are measured from the slewing centreline.

Remarques relatives aux tableaux des charges.

- Les forces de levage indiquées ne dépassent pas 75 % de la charge de basculement.
- Conformément au nouveau texte de loi paru au bulletin fédéral de février 1985, les normes DIN ci-après sont appliquées pour les calculs relatifs à la grue: charges à 75 % suivant les prescriptions de la norme DIN 15019, 2ème partie. La norme DIN 15018, 3ème partie est appliquée pour les charpentes. La construction de la grue est réalisée conformément à la norme DIN 15018, 2ème partie, et aux règles de la F. E. M.
- Les forces de levage sont données en tonnes.
- Le poids des mouffes et crochets doit être soustrait des charges indiquées.
- Les portées sont calculées à partir de l'axe de rotation.

Die Hubhöhen am S-Ausleger. Lifting heights at S boom. Hauteurs de levage à la flèche principale S.

LR 11200

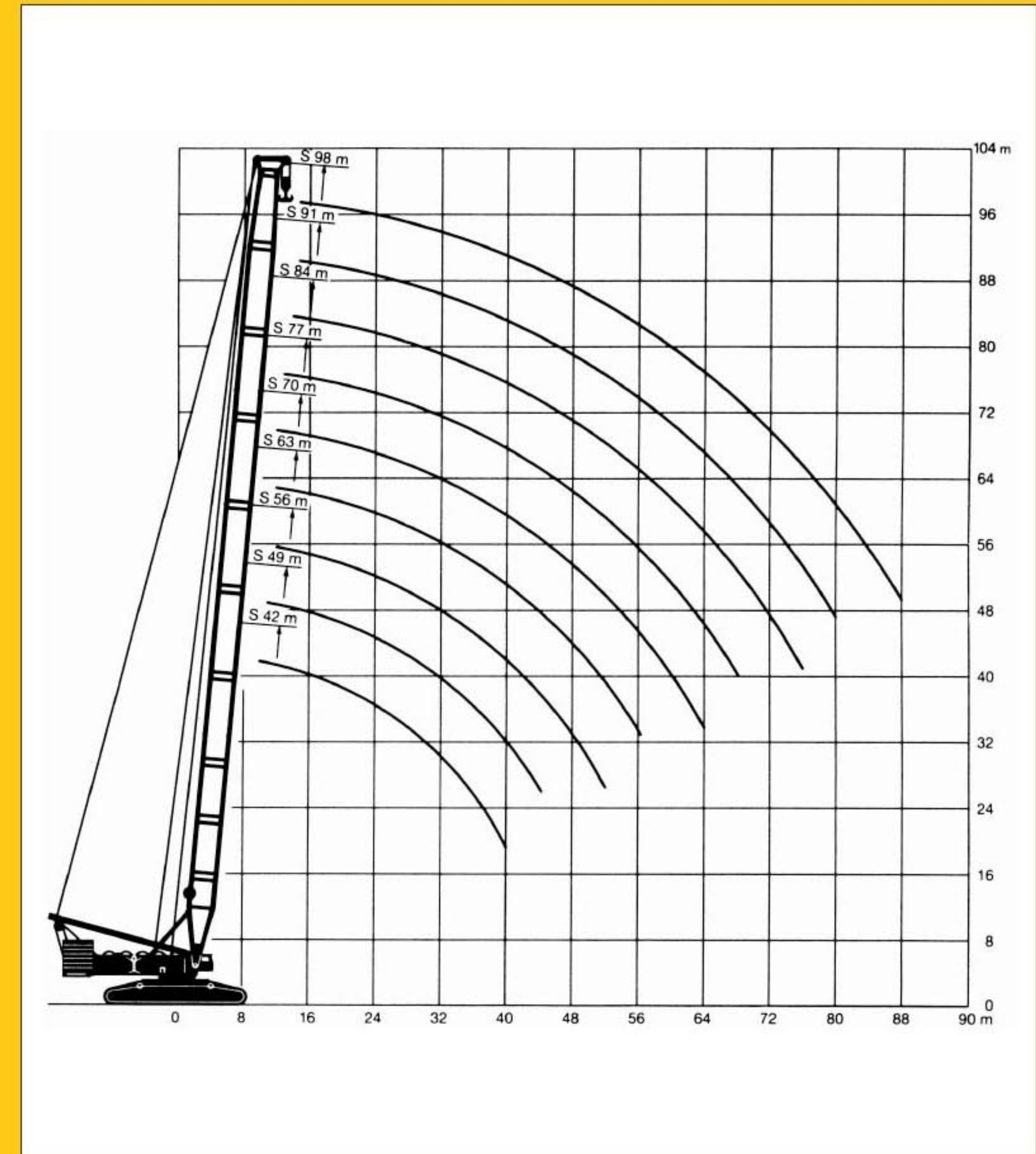

Sein größtes Lastmoment ist 20904 tm.

Die Traglasten am SD-Auslegersystem.
Lifting capacities at SD boom/derrick combination.
Forces de levage en configuration SD.

LR 11200



56 m - 126 m



42 m





12,8 m x 12,5 m



360°

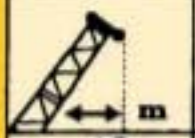

400 t

 m	56 m	63 m	70 m	77 m	84 m	91 m	98 m	105 m	112 m	119 m	126 m	 m
16	662	660										16
18	585	582	580									18
20	522	519	517	512	510							20
22	470	467	465	460	457	454	451					22
24	427	424	421	417	414	411	407	404	392			24
26	390	387	384	380	376	373	370	367	358	356		26
28	358	355	352	348	344	341	337	335	328	325	314	28
30	331	328	324	320	316	313	309	307	300	297	287	30
32	308	303	300	296	292	289	285	282	274	273	264	32
34	285	282	279	274	270	267	263	259	252	251	242	34
36	266	263	259	255	251	248	244	239	232	232	223	36
38	249	246	242	238	234	230	225	220	214	213	206	38
40	234	230	227	222	218	212	207	202	197	196	190	40
44	208	204	199	193	187	182	176	171	168	164	159	44
48	188	181	175	168	162	157	151	146	142	138	133	48
52	168	161	154	147	141	136	130	125	121	116	111	52
56		145	137	130	124	118	112	106	103	98	93	56
60			123	115	109	103	96	91	87	82	77	60
64			116	103	96	90	83	78	73	68	63	64
68				92	85	78	72	66	61	56	51	68
72					76	68	61	56	51	46	40	72
76					72	60	53	46	42	36	31	76
80						52	45	38	33	28	22	80
84							38	31	26	20		84
88								37	25	19		88
92									19			92
m/s*	14	13	13	13	13	11	11	11	11	9	9	m/s*

* Zulässige Windgeschwindigkeit.
 Permissible wind speed.
 Vitesse du vent admissible.

TAB 58043

Die Hubhöhen am SD-Auslegersystem.
Lifting heights at SD boom/derrick combination.
Hauteurs de levage en configuration SD.

LR 11200

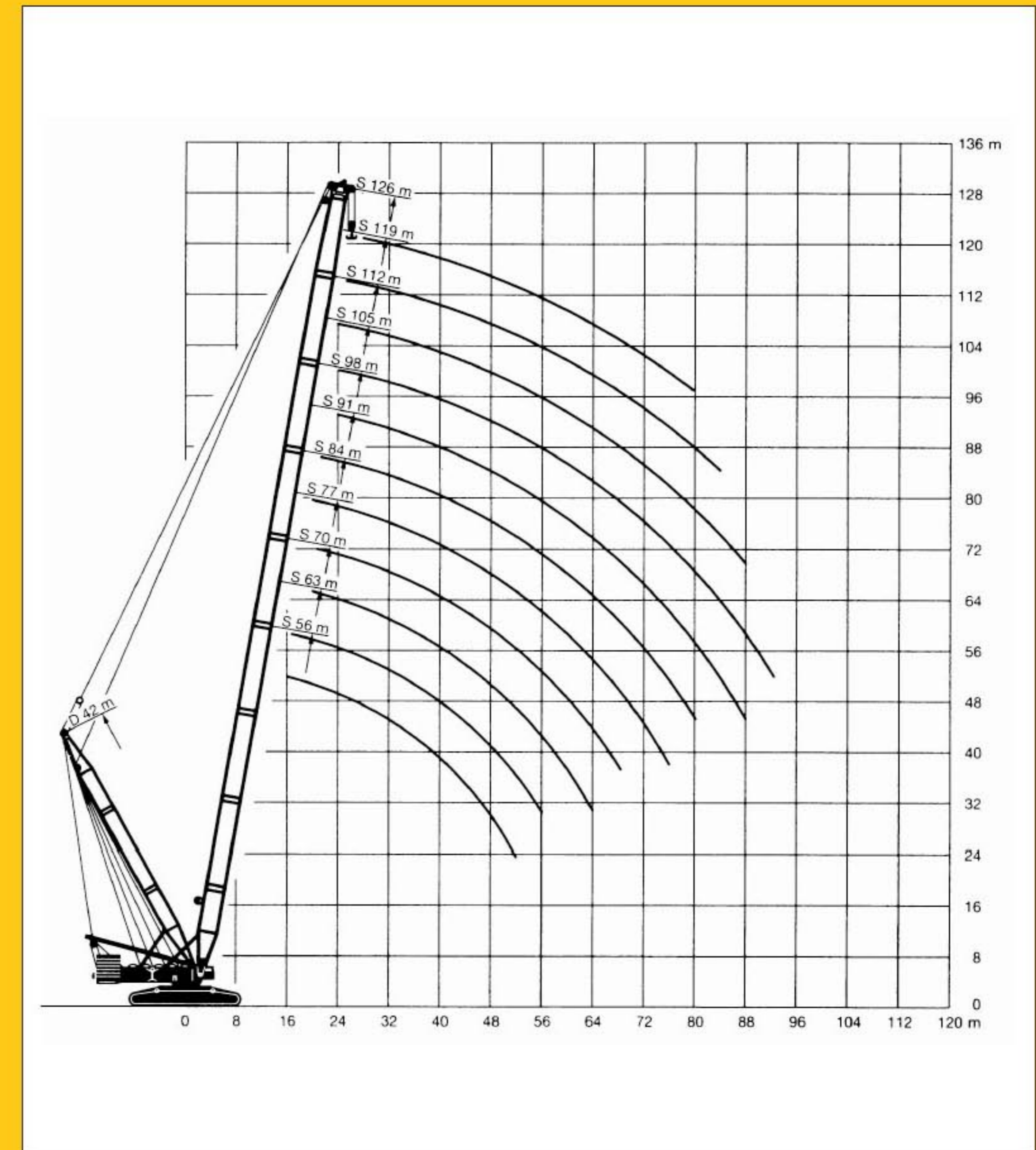

Its maximum load moment is 20904 tm.

Die Traglasten am SDBW-Auslegersystem.
Lifting capacities at SDBW boom/derrick combination.
Forces de levage en configuration SDBW.

LR 11200



m	56 m	63 m	70 m	77 m	84 m	91 m	98 m	105 m	112 m	119 m	126 m	m
16	1000	1000										16
18	1000	978	938									18
20	961	926	888	844	833							20
22	912	879	842	800	790	710	640					22
24	868	836	801	761	750	710	640	550	500			24
26	804	797	763	724	714	690	628	542	493	447		26
28	736	738	728	691	681	676	616	533	487	443	400	28
30	678	679	681	660	650	647	604	525	480	435	392	30
32	627	628	629	624	619	615	588	516	473	426	384	32
34	583	584	584	579	574	570	563	508	467	418	376	34
36	544	544	544	539	534	530	529	499	460	409	368	36
38	510	510	509	503	498	494	493	491	452	401	360	38
40	480	479	477	472	467	462	461	460	443	392	353	40
44	427	426	424	418	412	407	405	404	401	367	337	44
48	385	382	379	373	368	362	360	358	355	339	321	48
52	361	346	343	336	330	325	322	320	316	313	303	52
56		316	311	304	299	293	290	287	284	282	280	56
60			285	278	271	265	262	259	255	253	251	60
64			271	254	248	242	238	235	231	228	226	64
68				234	228	221	217	213	209	206	203	68
72					210	203	198	195	190	187	184	72
76						201	187	182	178	173	170	76
80							173	167	163	158	155	80
84								154	150	145	141	84
88									149	138	132	88
92										138	128	92
96											127	96
100												100
104												104
108												108
112												112
m/s*	14	13	13	13	13	11	11	11	11	9	9	m/s*

* Zulässige Windgeschwindigkeit.
 Permissible wind speed.
 Vitesse du vent admissible.

TAB 58046

Die Hubhöhen am SDBW-Auslegersystem.
Lifting heights at SDBW boom/derrick combination.
Hauteurs de levage en configuration SDBW.

LR 11200

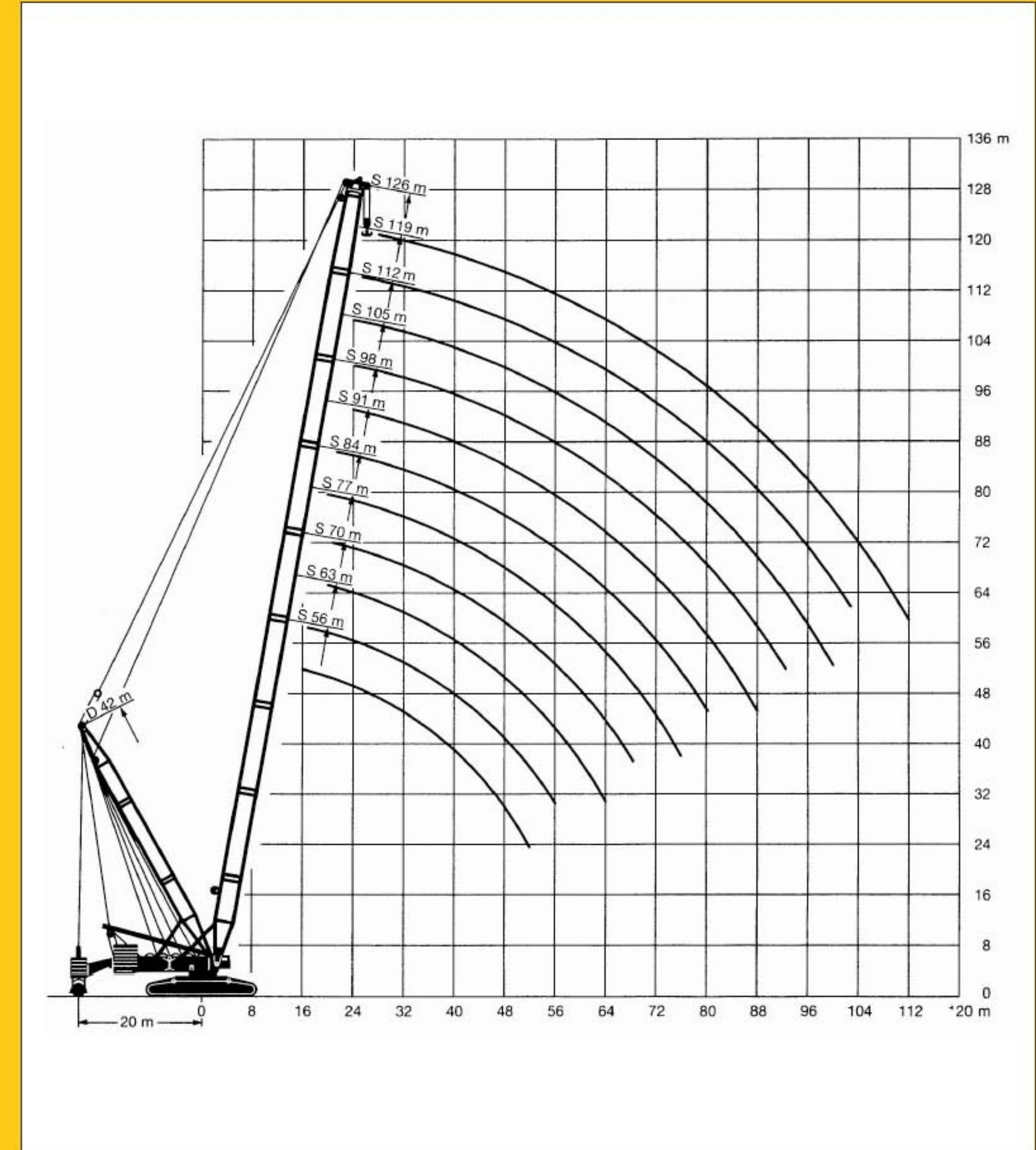

Couple charge maxi.: 20904 tm.

Die Traglasten am SN-Auslegersystem. Lifting capacities at SN boom/jib combination. Forces de levage en configuration SN.

LR 11200



m	42 m						56 m						m
	42 m	56 m	70 m	84 m	98 m	112 m	42 m	56 m	70 m	84 m	98 m	112 m	
24	300						269						24
26	297						268						26
28	293	210					266	197					28
30	289	209					263	197					30
32	284	208	158				260	196	148				32
34	278	207	155				257	195	145				34
36	272	205	152	114			253	194	142	106			36
38	265	203	149	113			247	192	139	105			38
40	257	200	145	112	82		241	190	136	104	77		40
44	233	193	139	110	80	59	227	184	131	102	75	55	44
48	189	184	133	107	79	57	198	177	125	100	74	53	48
52		174	127	105	77	54		168	119	98	72	51	52
56		163	120	103	75	52		158	113	96	71	48,5	56
60		143	114	101	74	50		147	107	94	69	46,5	60
64			108	98	72	47,5			102	93	68	44,5	64
68			101	96	70	45			96	91	66	42,5	68
72			95	94	69	43			90	89	65	40	72
76				92	67	40,5				87	63	38	76
80				89	65	38,5				85	62	36	80
84				85	64	36				83	60	34	84
88					62	34				75	59	31,5	88
92					60	31,5					57	29,8	92
96					59	29,2					56	27,5	96
100					57	26,9					54	25,4	100
104						24,8						23,2	104
108						22,3						21,1	108
112						20						19	112
m/s*	13	13	13	13	11	11	13	13	13	11	11	11	m/s*

* Zulässige Windgeschwindigkeit.
Permissible wind speed.
Vitesse du vent admissible.

TAB 68060

m	70 m						84 m					m
	42 m	56 m	70 m	84 m	98 m	112 m	42 m	56 m	70 m	84 m	98 m	
26	243											26
28	241						200					28
30	239	180					199					30
32	237	179					198	164				32
34	234	178	135				197	164				34
36	231	177	133	98			195	163	120			36
38	227	176	130	97			193	162	118			38
40	223	175	128	97	70		191	161	116	86		40
44	212	171	123	96	69		187	158	112	85	66	44
48	200	166	118	94	67	48	183	155	108	84	65	48
52		160	113	92	66	46	175	150	104	84	63	52
56		153	108	91	65	44,5		145	101	83	62	56
60		145	103	89	64	42,5		139	97	82	61	60
64		128	98	88	62	40,5		133	93	81	59	64
68			93	86	61	39			89	80	58	68
72			88	85	60	37			85	79	57	72
76			83	83	59	35			81	79	55	76
80				82	57	33,5				78	54	80
84				80	56	31,5				77	53	84
88				78	55	29,8				76	51	88
92					54	27,9					50	92
96					52	26,1					48,5	96
100					51	24,3					47,5	100
104						22,5					46	104
108						20,7						108
112						18,8						112
116						17						116
m/s*	13	13	11	11	11	9	13	11	11	11	9	m/s*

TAB 68060

Die Hubhöhen am SN-Auslegersystem. Lifting heights at SN boom/jib combination. Hauteurs de levage en configuration SN.

LR 11200

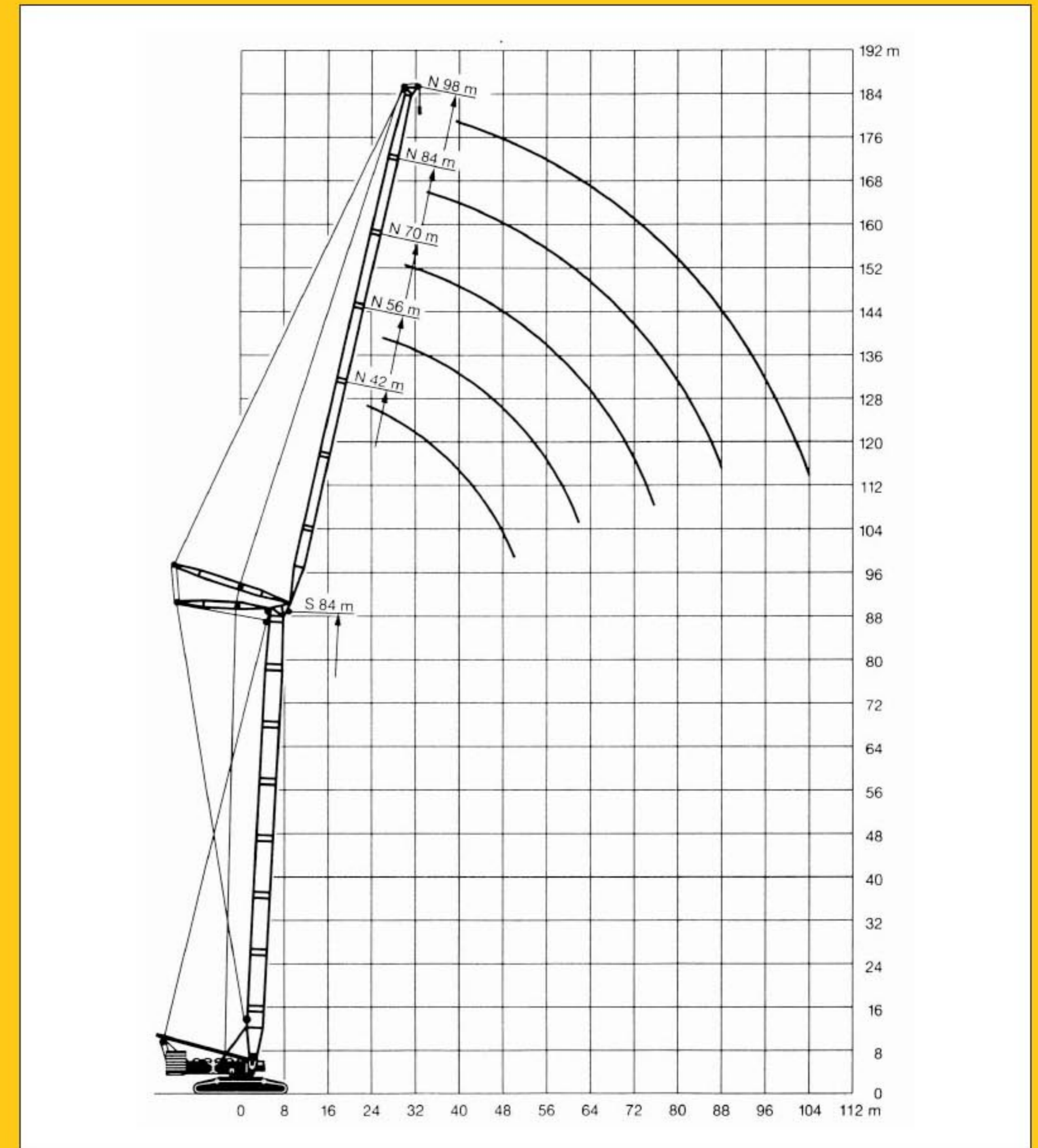

Die Traglasten am SDN-Auslegersystem. Lifting capacities at SDN boom/derrick/jib combination. Forces de levage en configuration SDN.

LR 11200



m	56 m						70 m						84 m						m	
	42 m	56 m	70 m	84 m	98 m	112 m	42 m	56 m	70 m	84 m	98 m	112 m	42 m	56 m	70 m	84 m	98 m	112 m		
24	300						274													24
26	296						272						252							26
28	292	213					267	202					247							28
30	288	211					263	200					242	189						30
32	283	209	160				257	197	147				238	186						32
34	277	206	157				247	195	144	112			231	183	138					34
36	263	204	153	118			234	182	142	111			219	180	135					36
38	249	202	150	115			223	189	139	110	81		208	177	133	105				38
40	237	199	148	113	84		202	183	133	107	79		189	171	128	103	76			40
44	215	194	140	111	82	63	186	178	128	106	77	57	174	165	123	101	74	54		44
48	194	187	133	108	80	61	163	128	105	77	57	57	160	152	118	98	72	52	52	48
52		173	126	106	79	59	151	117	100	74	53		141	113	96	70	50	50	50	52
56		168	119	103	77	56	141	111	97	72	51		131	107	94	69	48	48	48	56
60		144	112	101	75	54	128	106	95	70	48		122	102	92	67	46	46	46	60
64			106	98	73	52	100	93	68	46			97	89	65	44	42	42	42	64
68			99	96	71	50	96	90	67	44			92	87	63	42	42	42	42	68
72			92	93	70	47	89	88	65	42			87	85	61	40	40	40	40	72
76				91	68	45		85	63	40			83	59	38	38	38	38	38	76
80				88	66	43		83	61	38			79	57	36	36	36	36	36	80
84				86	64	41		78	59	36			75	55	34	34	34	34	34	84
88				75	62	38			58	34				54	32	32	32	32	32	88
92					61	36			56	32				52	30	30	30	30	30	92
96					59	34			54	29				50	28	28	28	28	28	96
100					57	32				27				48	26	26	26	26	26	100
104						29				27					24	24	24	24	24	104
108						27				25					24	24	24	24	24	108
112						25				23					22	22	22	22	22	112
116										21					20	20	20	20	20	116
m/s*	13	13	13	11	11	11	13	13	11	11	11	9	13	11	11	11	9	9	9	m/s*

* Zulässige Windgeschwindigkeit. Permissible wind speed. Vitesse du vent admissible. TAB 58049.1

m	98 m						112 m						126 m						m
	42 m	56 m	70 m	84 m	98 m	112 m	56 m	70 m	84 m	98 m	112 m	56 m	70 m	84 m	98 m				
28	223															28			
30	220															30			
32	217	170														32			
34	213	168														34			
36	210	166	126				144					118				36			
38	203	164	124				142					117				38			
40	193	162	122	94			141	107				116	89			40			
44	176	157	118	92	73		137	104	84			114	87	72		44			
48	161	153	114	90	71	51	134	100	82	63		112	85	70	50	48			
52	149	141	110	88	69	49	130	97	80	61	44	110	83	68	50	52			
56		131	106	86	67	47	120	94	78	60	42	107	81	66	50	56			
60		122	101	84	65	45	112	91	75	58	41	100	79	64	49	60			
64		114	97	82	63	43	104	87	73	56	39	93	76	62	48	64			
68			93	80	61	42		84	71	55	37	87	74	60	46	68			
72			89	78	59	40		81	69	53	36		72	58	45	72			
76			85	76	57	38		77	67	52	34		70	56	44	76			
80				74	55	36		74	65	50	32		67	54	43	80			
84				72	53	34			62	48	31			52	41	84			
88				68	51	32			60	47	29			50	40	88			
92				64	49	30			58	45	28			48	39	92			
96					47	28				43	26				38	96			
100					45	27				42	24				36	100			
104					43	25				40	23				35	104			
108						23					21				32	108			
112						21					19					112			
116						19					18					116			
120											16					120			
m/s*	11	11	11	9	9	9	11	9	9	9	9	9	9	9	9	m/s*			

TAB 58049.2

Die Hubhöhen am SDN-Auslegersystem. Lifting heights at SDN boom/derrick/jib combination. Hauteurs de levage en configuration SDN.

LR 11200

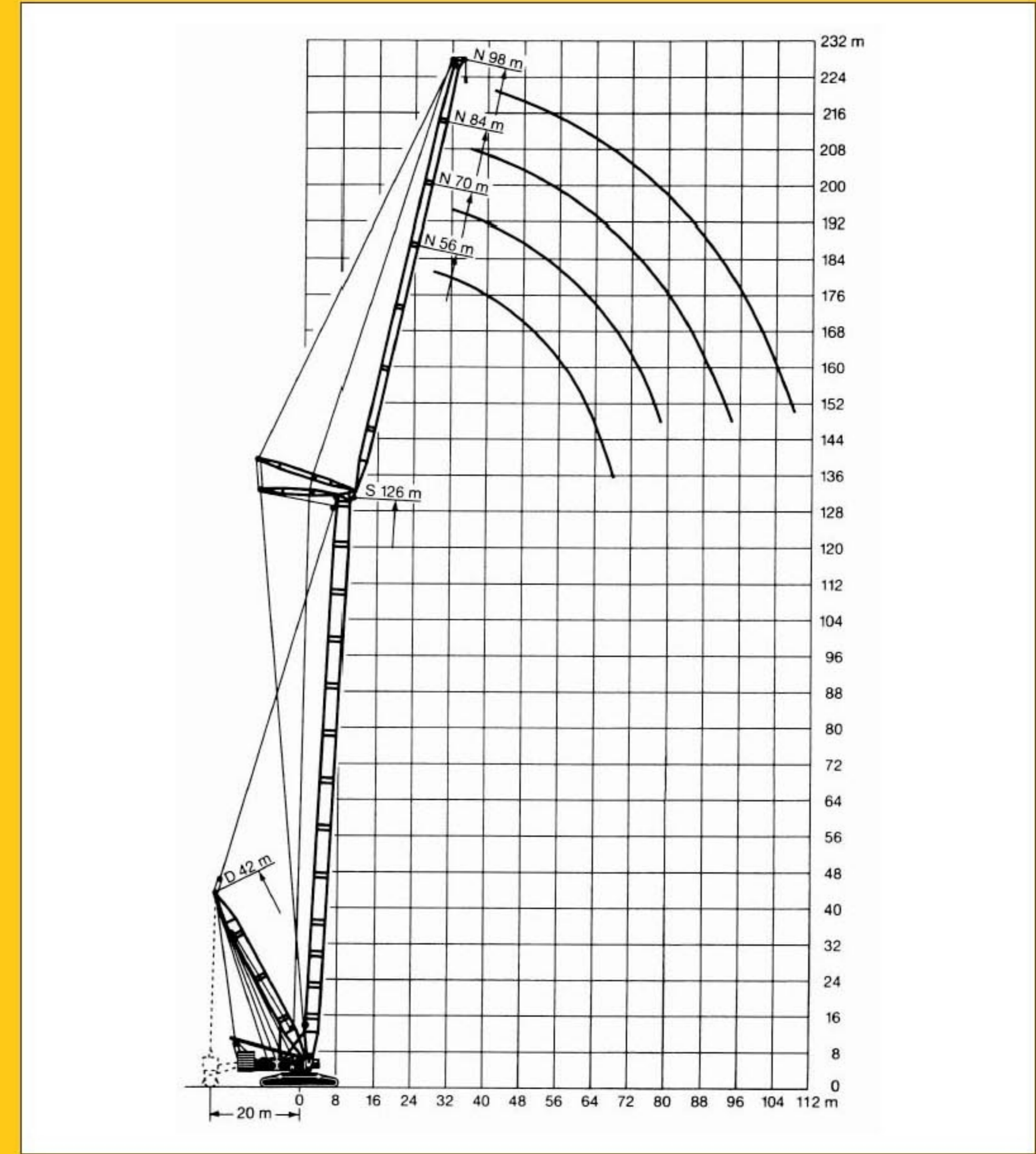

Die Traglasten am SDNBW-Auslegersystem.
Lifting capacities at SDNBW boom/derrick/jib combination.
Forces de levage en configuration SDNBW.

LR 11200



m	56 m						70 m						84 m						m	
	42 m	56 m	70 m	84 m	98 m	112 m	42 m	56 m	70 m	84 m	98 m	112 m	42 m	56 m	70 m	84 m	98 m	112 m		
60	292																			60
64	261																			64
68	224	203																		68
72		197																		72
76		188	124																	76
80		165	119																	80
84		140	114	107																84
88			108	107																88
92			103	107	70															92
96			98	107	69															96
100				107	69	40														100
104				99	68	39														104
108				88	68	38														108
112				76	67	37														112
116					66	36														116
120					66	35														120
124					62	34														124
128						33														128
132						32														132
136						31														136
140						30														140
144																				144
148																				148
152																				152
m/s*	13	13	13	11	11	11	13	13	11	11	11	9	13	11	11	11	9	9	m/s*	

TAB 58078.1

m	98 m						112 m						126 m						m
	42 m	56 m	70 m	84 m	98 m	112 m	56 m	70 m	84 m	98 m	112 m	56 m	70 m	84 m	98 m				
76	178															76			
80	168															80			
84	158	154														84			
88	149	145														88			
92		138	107													92			
96		130	105													96			
100		123	102	81												100			
104			100	81												104			
108			97	81	54											108			
112			95	81	54											112			
116			92	81	54	28										116			
120				81	54	28										120			
124				81	54	27										124			
128				80	53	27										128			
132					53	26										132			
136					53	26										136			
140					53	25										140			
144					53	25										144			
148						24										148			
152						24										152			
156						23										156			
160																160			
164																164			
m/s*	11	11	11	9	9	9	11	9	9	9	9	9	9	9	9	m/s*			

TAB 58078.2

Die Hubhöhen am SDNBW-Auslegersystem.
Lifting heights at SDNBW boom/derrick/jib combination.
Hauteurs de levage en configuration SDNBW.

LR 11200

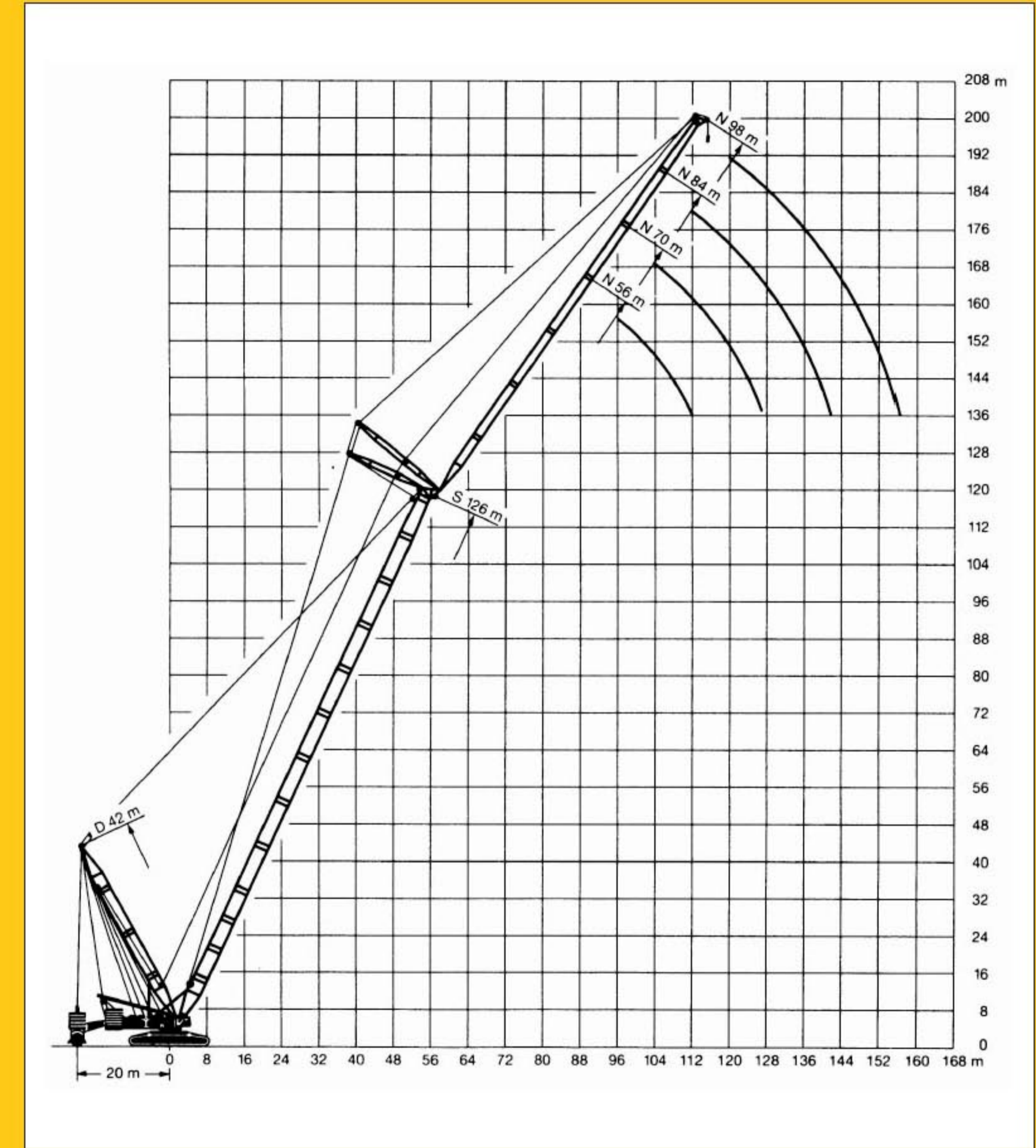

Die Traglasten am SDWBW-Auslegersystem. Lifting capacities at SDWBW boom/derrick/jib combination. Forces de levage en configuration SDWBW.

LR 11200



m	56 m					70 m					84 m					m
	42 m	56 m	70 m	84 m	98 m	42 m	56 m	70 m	84 m	98 m	42 m	56 m	70 m	84 m	98 m	
22	600															22
24	585					500					410					24
26	570	450				488	390				402					26
28	557	440				476	381				394	325				28
30	542	430	350			464	373	310			385	319				30
32	528	420	342	260		453	365	302			377	313	265			32
34	513	410	335	256		441	357	296	230		368	307	261			34
36	498	400	328	252	195	430	350	291	226		360	301	257	200		36
38	484	390	320	247	192	418	342	285	222	172	352	295	252	197		38
40	470	380	314	243	190	406	334	280	218	170	344	289	247	193	145	40
44	440	360	300	234	186	383	318	268	210	166	327	277	239	187	142	44
48		340	285	225	182	360	302	257	203	162	310	265	230	180	139	48
52		320	270	217	178		286	245	196	158		254	222	174	136	52
56		300	257	208	174		270	234	188	154		242	213	168	133	56
60		280	243	200	170		255	223	181	150		230	205	161	130	60
64			228	191	163			212	173	144			196	155	125	64
68			214	183	155			200	166	138			187	148	120	68
72			200	174	149			190	158	132			178	141	115	72
76				166	142				151	126			170	135	110	76
80				157	135				144	120				128	105	80
84					150				137	113				122	99	84
88					121				130	107				115	93	88
92					114					100					87	92
96					107					94					82	96
100					100					88					76	100
m/s*	13	13	13	11	11	13	13	11	11	11	13	11	11	11	9	m/s*

TAB 55110

m	98 m					112 m				m
	42 m	56 m	70 m	84 m	98 m	56 m	70 m	84 m	98 m	
26	310									26
28	305									28
30	301	260								30
32	296	255				190				32
34	292	251	210			187				34
36	287	247	207			184	153			36
38	283	243	204	158		181	150			38
40	278	239	202	156	115	178	147	110		40
44	269	231	197	151	113	172	142	106	80	44
48	260	223	191	146	110	166	138	103	77	48
52		215	186	141	108	161	133	100	75	52
56		207	181	137	106	156	128	97	73	56
60		200	176	132	104	150	123	95	71	60
64		190	170	128	101	144	118	92	69	64
68			165	123	98		114	89	67	68
72			160	118	96		108	86	65	72
76			155	114	93		104	83	63	76
80				109	90			79	61	80
84				105	85			76	59	84
88				100	80			73	57	88
92					75			70	55	92
96					70				53	96
100					65				50	100
104									48	104
m/s*	11	11	11	9	9	11	9	9	9	m/s*

TAB 55110

Die Hubhöhen am SDWBW-Auslegersystem. Lifting heights at SDWBW boom/derrick/jib combination. Hauteurs de levage en configuration SDWBW.

LR 11200

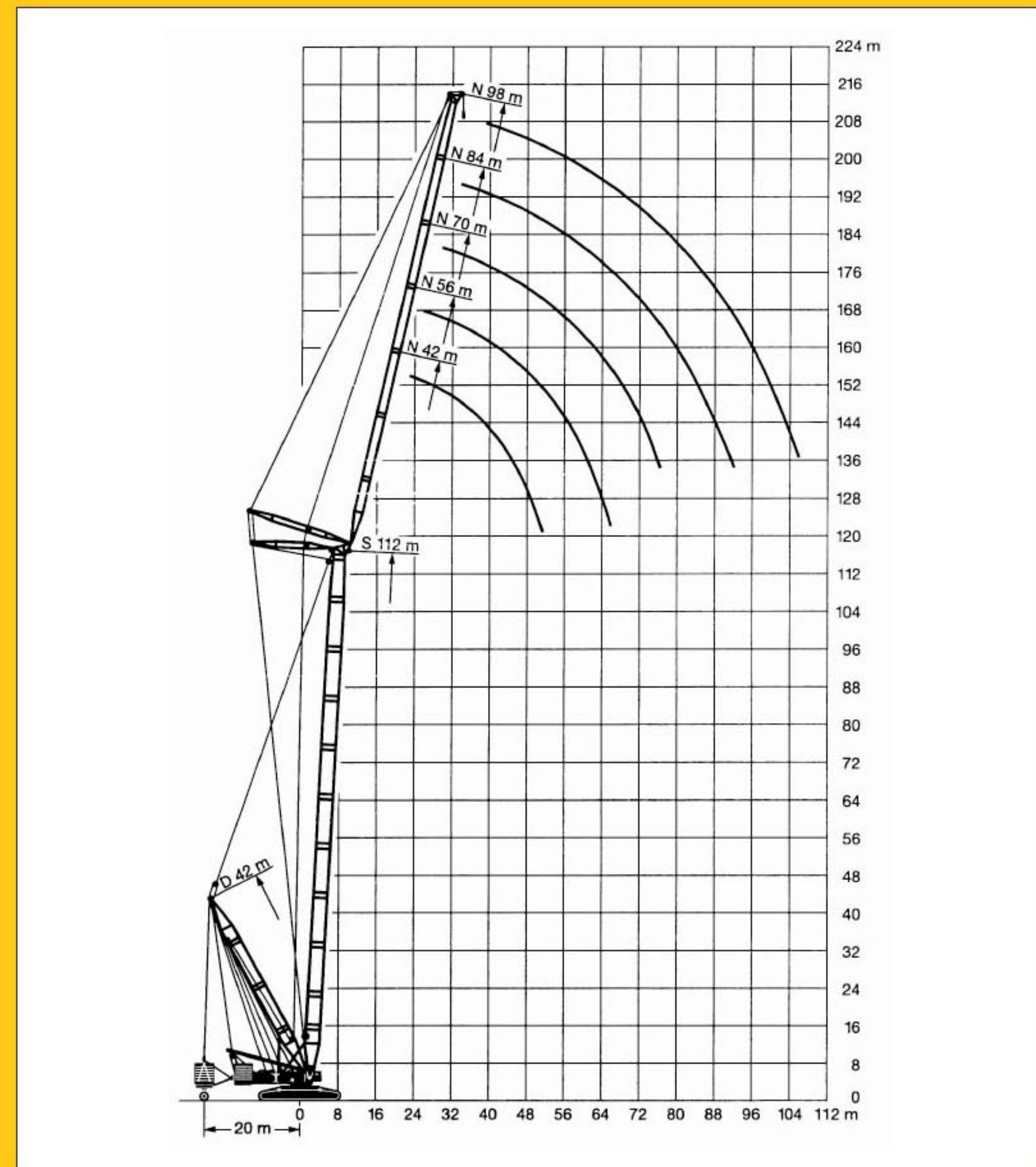

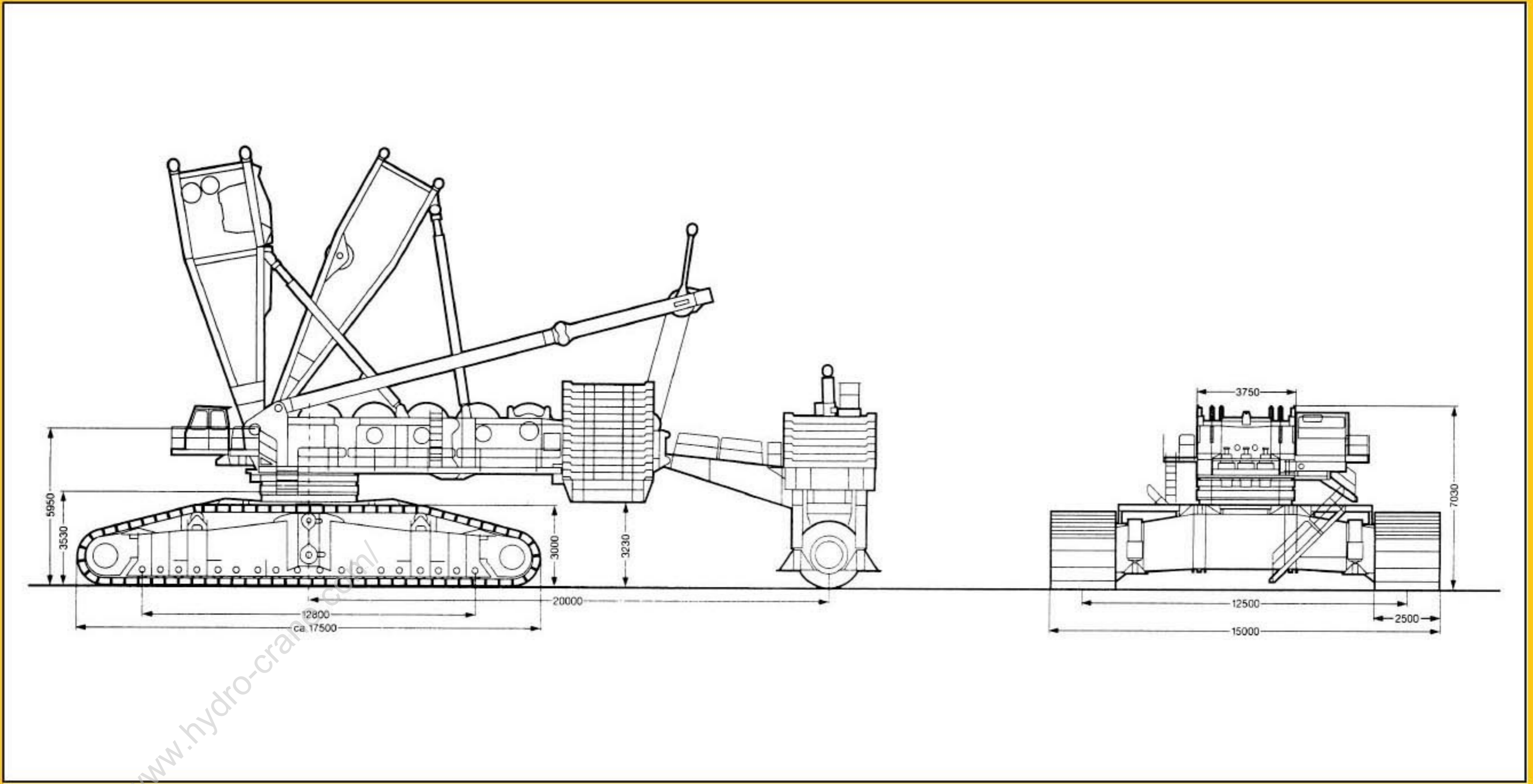

**Die Maße.
Dimensions.
Encombrement.**

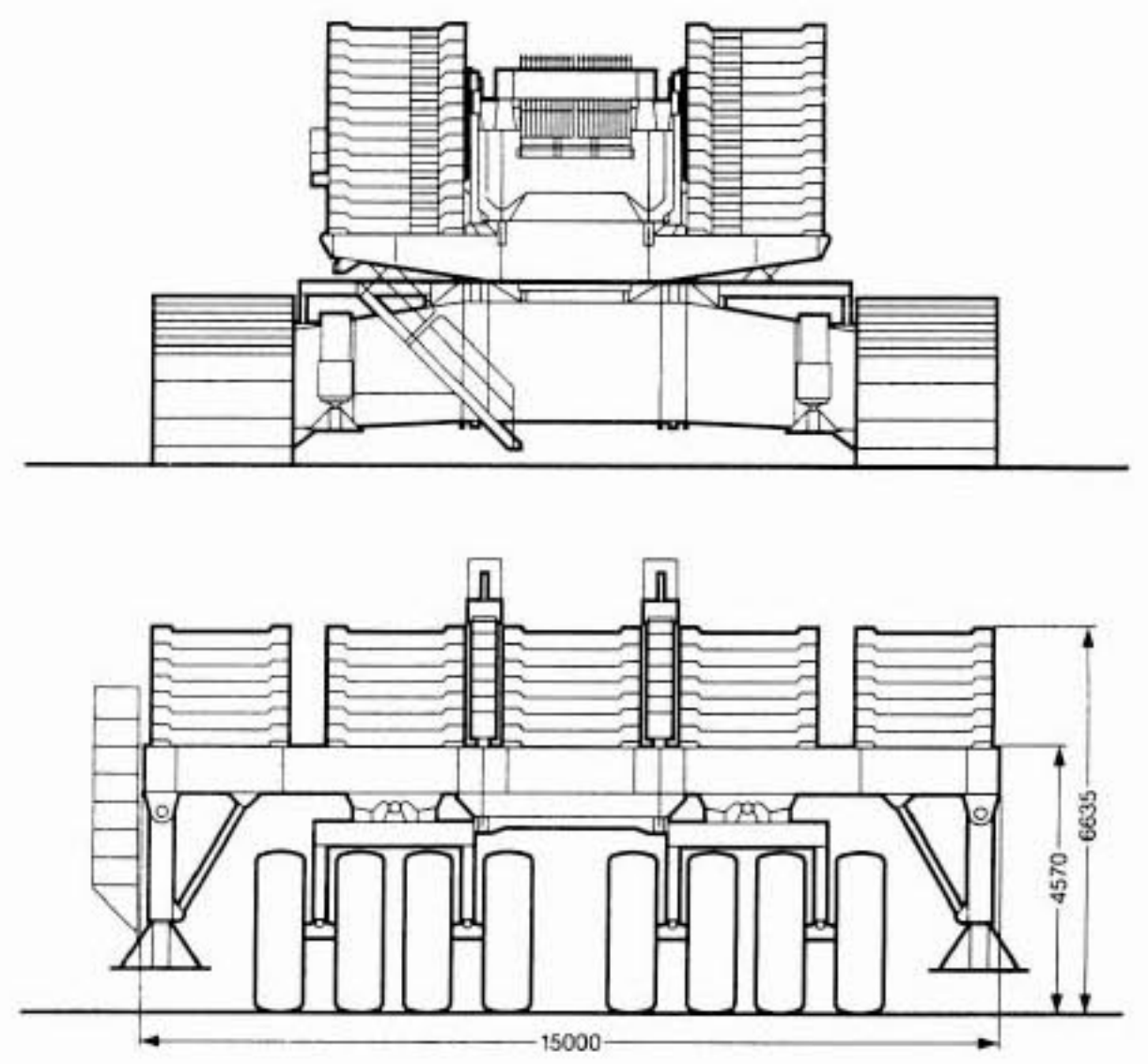
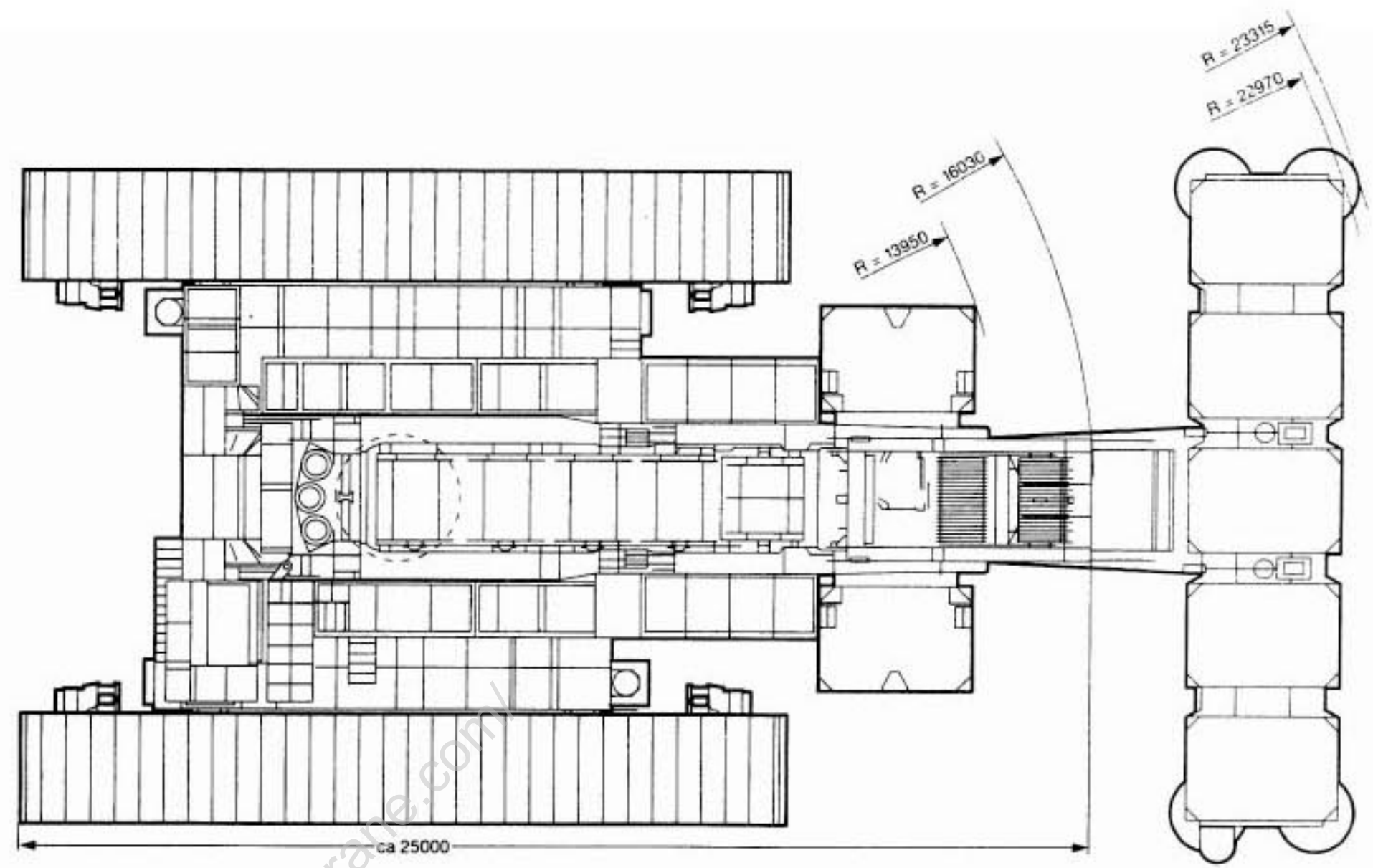

<http://www.hydro-craie.com/>

Das Raupenfahrwerk.

Rahmen:	Eigengefertigte, verwindungssteife Schweißkonstruktion aus hochfestem Feinkorn-Baustahl. Bestehend aus Mittelteil, 2 Querträgern und 2 zweigeteilten Raupenträgern.
Laufwerk:	Wartungsfreies, schmutzgeschütztes Raupenfahrwerk mit Flachbodenplatten. Plattenbreite: 2,5 m, Spurbreite: 12,5 m.
Antrieb:	Pro Raupenträger 2 hydraulische Fahrtriebe mit Planetengetrieben. Die Raupenkettens sind unabhängig und gegenläufig steuerbar, es gibt keine bevorzugte Fahrtrichtung.

Der Kranoberwagen.

Rahmen:	Eigengefertigte, verwindungssteife Schweißkonstruktion aus hochfestem Feinkorn-Baustahl. Verbindung zum Fahrwerk über 3reihige Rollendrehverbindung mit Quick Connection, 360° schwenkbar, Oberwagen geteilt.
Motor:	Cummins, 12-Zylinder, Typ KTA 38 C 1050, 746 kW (1014 PS) bei 1800 min ⁻¹ .
Kranantrieb:	Hydraulisch über Pumpen verteilergetriebe mit 5 Axialkolben-Verstellpumpen mit Leistungsregelung, geschlossene Ölkreisläufe.
Kransteuerung:	Servosteuerung mit elektronischer Gleichlaufeinrichtung an den Hubwinden, Energierecycling beim Senken der Last. Alle Bewegungen werden unabhängig voneinander über Kreuzsteuerhebel gefahren.
Winden:	5 - 6 Winden hydraulisch angetrieben über Axialkolben-Verstellpumpen und Planetengetriebe, Lamellenbremse, federbelastet und hydraulisch lüftbar.
Drehwerk:	1 - 3 Drehwerke, hydraulisch angetrieben über Axialkolbenpumpe und Planetengetriebe. Lamellenbremsen, federbelastet und hydraulisch lüftbar. Drehgeschwindigkeit stufenlos regelbar.
Gegengewicht:	Ca. 400 t bestehend aus: 1 Ballastrahmen mit 14 t und 26 Platten à 15 t.
Krankabine:	Stahlblechausführung mit Sicherheitsverglasung, seitlich schwenkbar und nach hinten neigbar, mit Bedienungs- und Kontrollinstrumenten.
Elektrische Anlage:	24 V Gleichstrom, 2 Batterien à 143 Ah.

Auslegersysteme.

Schwere Ausführung:	S - SH - SN - SNH - SNF - SD - SDH - SDBW - SDN - SDNH - SDNBW - SDNF - SDWBW.
Zusatzeinrichtung:	Ballastwagen für 600 t Gesamtgewicht.

Die Lastaufnahmemittel. Hook blocks. Organes de préhension.

Traglast t Load (metric tons) Forces de levage t	Rollen No. of sheaves Poules	Stränge No. of lines Brins	Gewicht t Weight t Poids t
1000	14	30	32
500	7	15	16
400	7	15	20
200	3	7	10
90	1	3	7,5
30	-	1	2,5

Die Geschwindigkeiten. Working speeds. Vitesses.

Die Krangeschwindigkeiten.
Speeds of crane movements.
Vitesses de travail de la grue.

Antriebe Drive Entraînement	Hubwerk I Hoisting gear I Mécan. de levage I	Hubwerk II Hoisting gear II Mécan. de levage II	Verteilwinde I Luffing gear I Mécan. de relevage I	Verstellwinde II Luffing gear II Mécan. de relevage II	Einziehwerk Luffing gear Mécan. de relevage	Drehwerk Slewing gear Orientation
Geschwindigkeiten Speeds Vitesses	0 - 130 m/min	0 - 130 m/min	120 m/min	120 m/min	2 x 50 m/min	0 - 0,8 min ⁻¹
Max. Seilzug Max. rope tension Effort max. sur brin	310 kN	310 kN	336 kN	336 kN	2 x 336 kN	-
Seillänge Rope length Longueur du câble	1400 m	1400 m	1150 m	1150 m	2 x 770 m	-
Seildurchmesser Rope diameter Diamètre du câble	40 mm	40 mm	40 mm	40 mm	40 mm	-